

# TRIS70x200NX/L-70x250NX/L-70x200NX-70x250NX Segnaletica



## SCHEDA TECNICA



### STRUTTURA

-  MATERIALE: alluminio/metallo
-  FINITURA: silver
-  INDOOR/OUTDOOR
-  CERTIFICATO DI STATICITÀ
-  FISSAGGIO A TERRA

### SUPERFICIE

-  MATERIALE: forex
-  FINITURA: bianco

### GRAFICA

-  GRAFICA ADESIVA
-  TRIFACCIALE

Struttura trifacciale per esterni e interni a linea arcuata realizzata con profilo unico in alluminio anodizzato silver. Base con fori per il fissaggio a terra e terminale superiore in metallo verniciati a polveri silver. Tre superfici espositive in lamiera. Certificato di staticità.

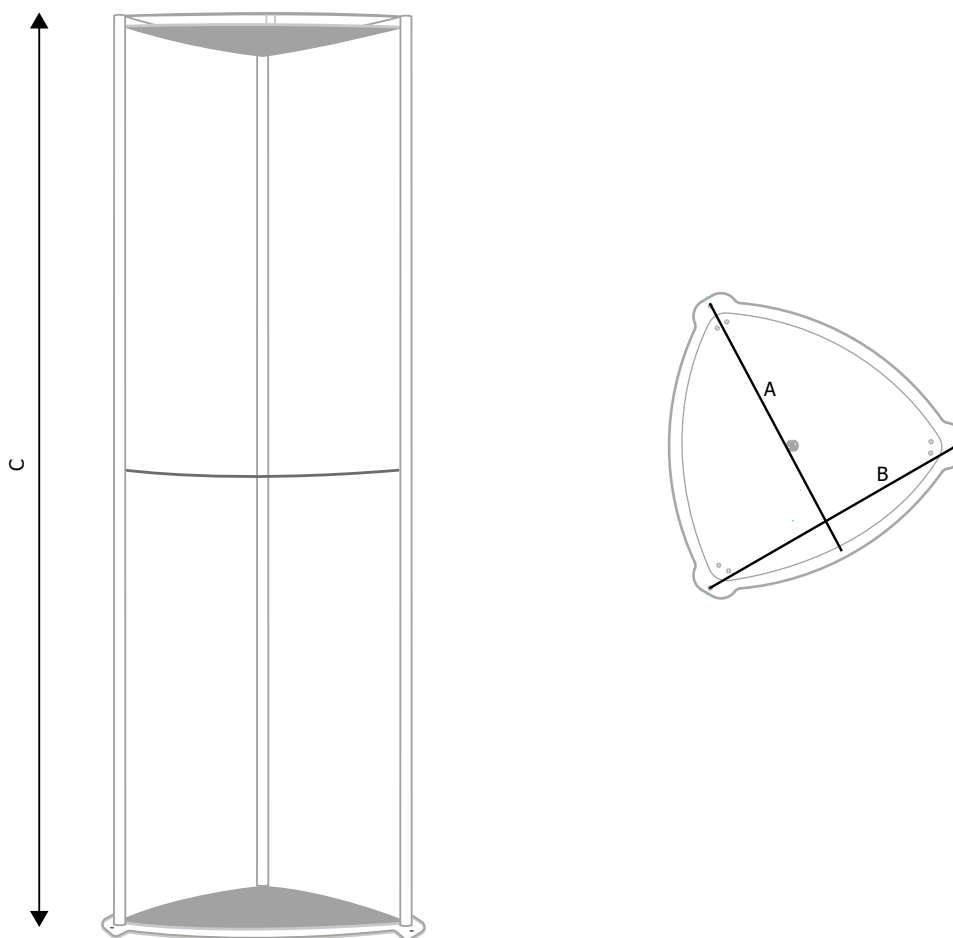
**TRIS70x200NX/L-70x250NX/L-70x200NX-70x250NX**  
**Segnaletica**
**SCHEDA TECNICA**

**DIMENSIONI PRODOTTO (mm)**

Codice	Locazione	Formato	Area visibile	Dim. struttura (AxBxC)	Cod. EAN
<b>TRIS70x200NX</b>	interno	700x2000	670x2000	700x350x2000	0768855793446
<b>TRIS70x250NX</b>	interno	700x2500	670x2500	700x350x2500	0768855793453
<b>TRIS70x200NX/L</b>	esterno	700x2000	670x2000	700x350x2000	0768855793422
<b>TRIS70x250NX/L</b>	esterno	700x2500	670x2500	700x350x2500	0768855793439

**MISURE IMBALLO (mm/kg)**

Codice	Dim. imballo	Peso art.	Peso art. e imballo
<b>TRIS70x200NX</b>	800x800x2150	48,00	52,00
<b>TRIS70x250NX</b>	800x800x2650	53,00	56,00
<b>TRIS70x200NX/L</b>	800x800x2150	48,00	52,00
<b>TRIS70x250NX/L</b>	800x800x2650	53,00	56,00