

SLV19-19/N Espositori Pubblicitari

SCHEDA TECNICA



SLV19



SLV19/N



SITSTEMA GIREVOLE



STRUTTURA



MATERIALE STRUTTURA: alluminio/metallo



FINITURA MONTANTE: anodizzato silver



FINITURA BASE: verniciata silver RAL 9006



FINITURA MONTANTE E BASE: verniciato nero RAL 9005



MATERIALE PORTA DEPLIANT: styrene



INDOOR



GIREVOLE

Espositore a pavimento girevole, composto da base circolare in metallo con diametro 300 mm. Montante in alluminio ovale diametro 70x45 mm e porta depliant girevole in styrene trasparente per formato A4.

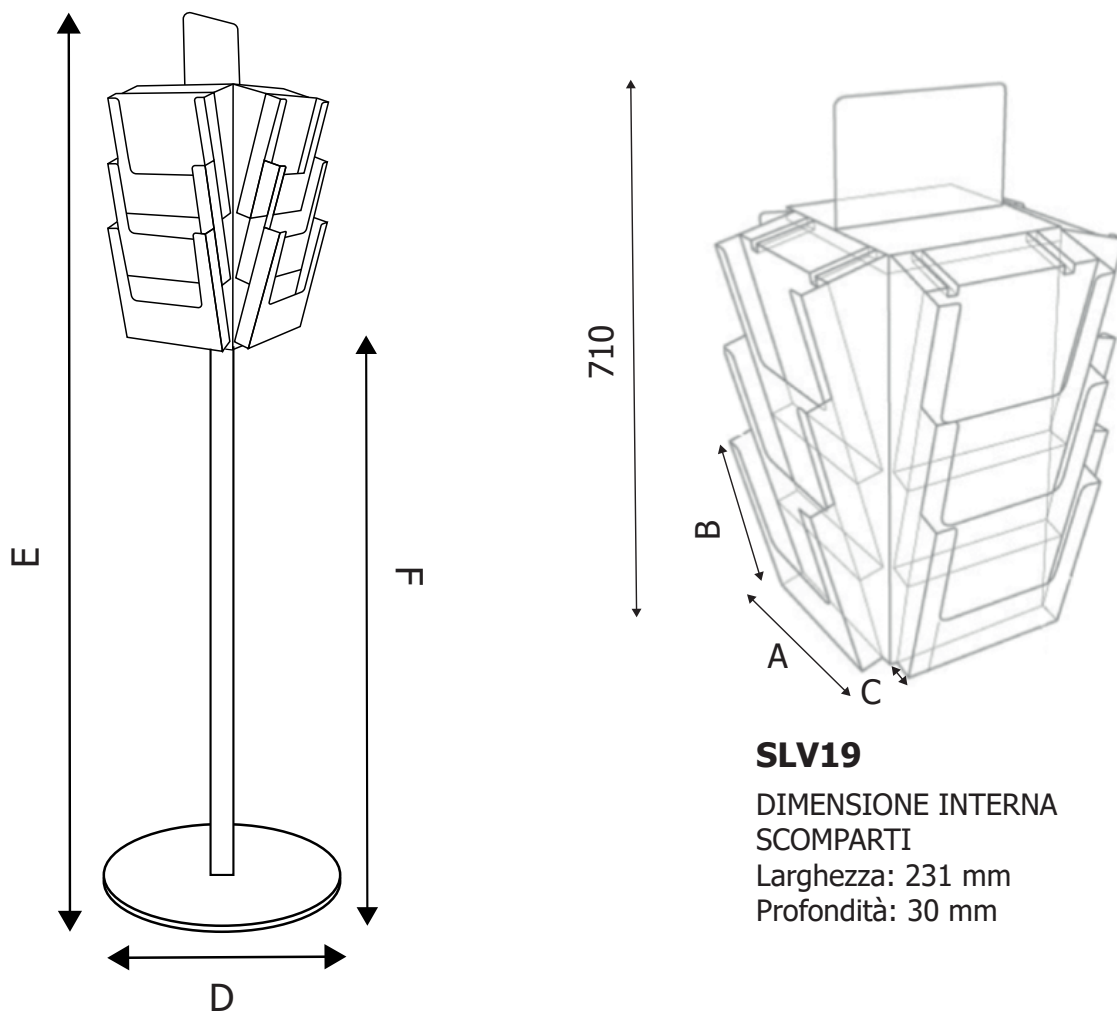
DIMENSIONI PRODOTTO (mm)

Codice	F.to tasche	N. Tasche	Dim. tasca (AxBxC)	Dim. struttura (DxFxE)	Montante Ø	Cod. EAN
SLV19	A4	12	237x248x36	450x1125x1835	70x45	0768855771802
SLV19/N	A4	12	237x248x36	450x1125x1835	70x45	0768855794009