

CMA003 Cavalletti in metallo

SCHEDA TECNICA



STRUTTURA



MATERIALE: metallo



FINITURA: nero



INDOOR/OUTDOOR



TRASPORTABILE

GRAFICA



GRAFICA INTERCAMBIABILE



BIFACCIALE

Cavalletto bifacciale con struttura e piedini in metallo verniciato a polveri nero. Dotato di maniglia per il trasporto. Apertura superiore per l'inserimento del pannello promozionale, dimensioni 600x900 mm con spessore 5mm. Profili laterali e inferiori con inserto per accogliere la grafica. Pannello promozionale non incluso.

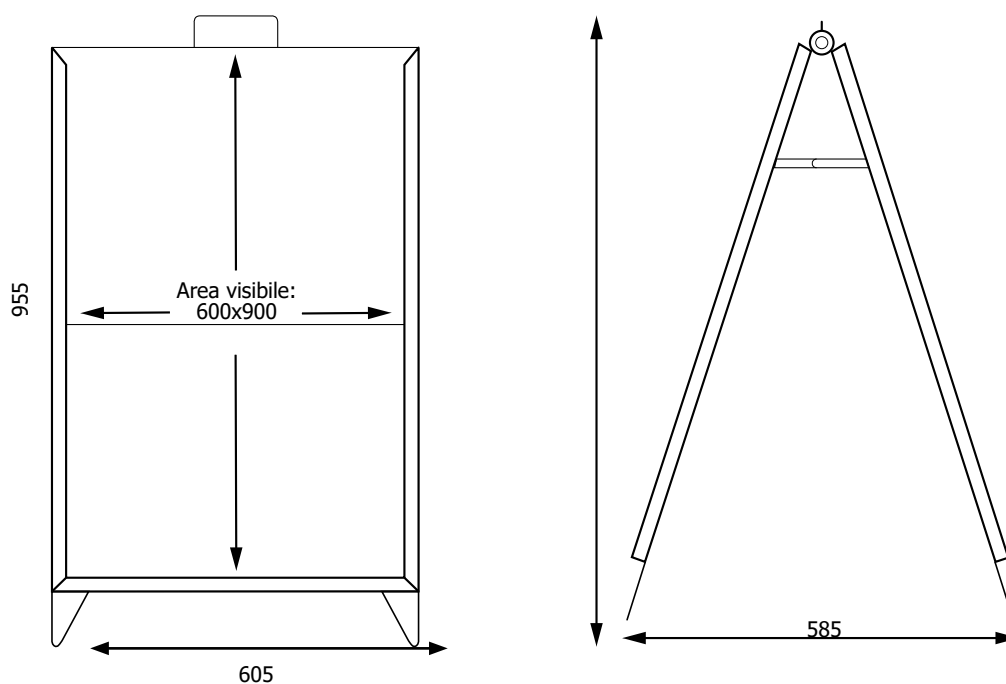
DIMENSIONI PRODOTTO (mm)

Codice	Area visibile	Spessore pannello	Dimensioni (AxBXC)	Cod. EAN
CMA003	600x900	consigliato da 3 a 5 mm	605x955x585	0768855790490

MISURE IMBALLO (mm/kg)

Codice	Dimensioni	Peso art.	Peso art. e imballo	Cod. EAN
CMA003	645x50x1040	3,4	4,5	0768855790490