

CRBZ100x140-70x100 Espositori a cavalletto

SCHEMA TECNICA



STRUTTURA



MATERIALE: alluminio anodizzato / abs



FINITURA CORNICE: silver



FINITURA BASE: grigio



INDOOR/OUTDOOR

GRAFICA



GRAFICA INTERCAMBIABILE



BIFACCIALE

Cavalletto bifacciale per esterni con molle anti-vento e base zavorrabile con acqua o sabbia, completa di ruote per il trasporto e piedini su entrambi i lati. Tasca ermetica contro umidità e acqua.

CRBZ100x140-70x100

Espositori a cavaletto

SCHEDA TECNICA

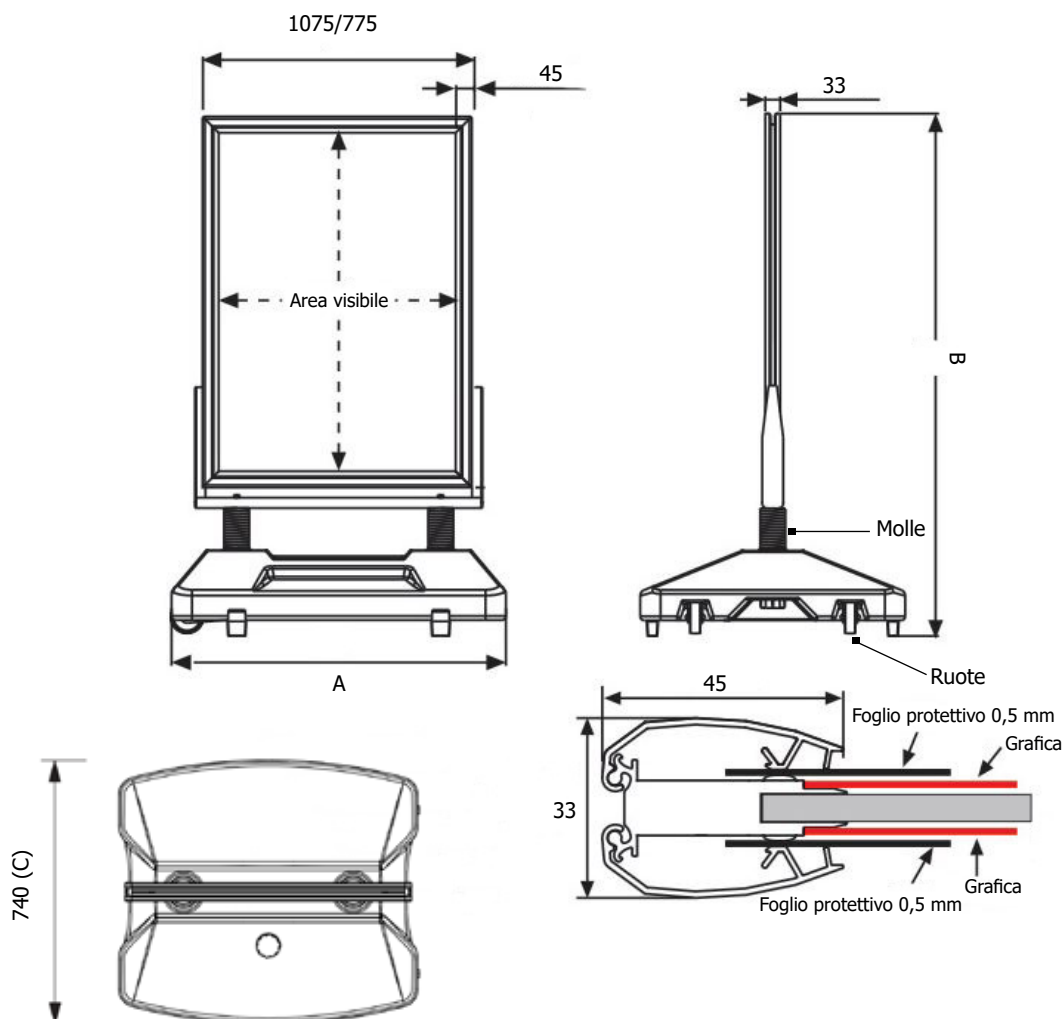

SISTEMA APERTURA A SCATTO

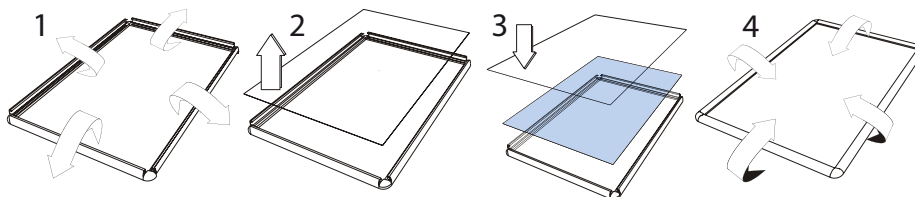

DIMENSIONI PRODOTTO (mm)

Codice	F.to poster	F.to visibile	Dim. totale (AxBxC)	Cod. EAN
CRBZ100x140	(2x) 1025x1425	(2x) 988x1388	1115x1865x740	0768855793736
CRBZ70X100	(2X) 725x1025	(2x) 688x988	777x1077x740	0768855793729

MISURE IMBALLO (mm/kg)

Codice	Dim. imballo	Peso art.	Peso art. e imballo
CRBZ100x140	1115x1720x40 + 750x1070x240	12,7 + 12,7	13,3 + 13,2
CRBZ70X100	815x1320x40 + 605x930x178	9,5 + 6	10,2 + 6,8